



OFFICE OF THE NATIONAL COMMANDER  
NATIONAL HEADQUARTERS  
CIVIL AIR PATROL  
UNITED STATES AIR FORCE AUXILIARY  
MAXWELL AIR FORCE BASE, ALABAMA 36112-5937

7 April 2020

MEMORANDUM FOR ALL UNIT COMMANDERS

FROM: CAP/CC

SUBJECT: Mission Essential Operations Only during Coronavirus COVID-19

1. Every state and U.S. territory has reported cases of COVID-19. Shelter-in-place or similar restrictive orders now cover 43 CAP Wings. To date, less than 100 CAP members have reported being tested and fewer than 20 have tested positive for COVID-19.
2. None of the positive cases can be directly attributed to CAP missions which may indicate that the measures in place to limit exposure have been effective. As the virus continues to spread, CAP must continue to take action to help protect the most high-risk populations while preserving our capability to respond when called upon.
3. In addition to the guidance provided previously in my 14 March 2020 memo, I am directing the following actions effective today:
  - a. All members must postpone non-mission essential in-person CAP operations and activities through 11 May 2020. Mission essential is defined as those missions that involve search and rescue and have the potential to prevent loss of life or property, provide critical homeland defense support and warfighter training, or support disaster relief and other emergency response and recovery operations including COVID-19 support.
  - b. Routine training, proficiency and flight evaluations must be postponed. Proficiency and flight evaluations will only be accomplished to meet established mission essential requirements. For example, if it is necessary to complete a short proficiency sortie immediately prior to a mission sortie to regain FAA passenger carrying requirements, that would be permissible.
  - c. Sorties to accomplish aircraft and vehicle maintenance are authorized.
  - d. If it is necessary to assemble personnel in one location to accomplish an essential mission, ICs must ensure that proper hand washing facilities are available, hand sanitizer is available, common surfaces like tables and chairs, handrails, doorknobs, keyboards and other high-touch surfaces are cleaned every four hours or as shifts change (whichever occurs first), and six foot social distancing practices are followed.
  - e. Mission pilots and vehicle drivers will clean commonly touched surfaces (including door handles, knobs, steering wheels and aircraft high-touch surfaces like control yokes, radio knobs, switches, visors, etc.) before and after each use to limit the potential for exposure.

f. Review the videos on the [COVID-19 Information Center](#) of GoCivilAirPatrol.com for [Cleaning and Disinfecting Aircraft and Vehicles](#) and [Cleaning and Disinfecting Garmin Aviation Products](#) and complete this process between personnel changes.

g. Effective immediately, all personnel supporting essential missions must wear cloth face coverings as outlined on the attached CDC guidance when circumstances prevent the mandate to maintain six feet of social distance in public areas or work centers including vehicles and aircraft. If homemade face coverings are worn in an aircraft, they must not impede the ability to clearly broadcast on the aircraft radio. Please note that security checkpoints at military and other government facilities may require the lowering of face covers to verify identity.

h. CAP should and must take every precaution possible to protect our members, front line workers and volunteers supporting other efforts, and the general public. CAP leads by example and our example should be one of strict adherence to CDC guidelines and best practices.

4. This guidance is effective 7 April 2020. Questions should be directed to the Director of Operations, John Desmarais, at [jdesmarais@capnhq.gov](mailto:jdesmarais@capnhq.gov).



MARK E. SMITH  
Major General, CAP  
National Commander

Attachment:  
CDC Face Covering Guidance

cc:  
CAP/CV/XO/CCC/COO/DO/GC/GVR/LG/PA/SE  
CAP-USAF/CC/CV/DO/DT/JA/LG/SE  
All CAP Region and Wing CV/CS/DC/DO/DOC/DOH/DOS/DOV/LG/SE

# Use of Cloth Face Coverings to Help Slow the Spread of COVID-19

## How to Wear Cloth Face Coverings

Cloth face coverings should—

- fit snugly but comfortably against the side of the face
- be secured with ties or ear loops
- include multiple layers of fabric
- allow for breathing without restriction
- be able to be laundered and machine dried without damage or change to shape

## CDC on Homemade Cloth Face Coverings

CDC recommends wearing cloth face coverings in public settings where other social distancing measures are difficult to maintain (e.g., grocery stores and pharmacies), **especially** in areas of significant community-based transmission.

CDC also advises the use of simple cloth face coverings to slow the spread of the virus and help people who may have the virus and do not know it from transmitting it to others. Cloth face coverings fashioned from household items or made at home from common materials at low cost can be used as an additional, voluntary public health measure.

Cloth face coverings should not be placed on young children under age 2, anyone who has trouble breathing, or is unconscious, incapacitated or otherwise unable to remove the cloth face covering without assistance.

The cloth face coverings recommended are not surgical masks or N-95 respirators. Those are critical supplies that must continue to be reserved for healthcare workers and other medical first responders, as recommended by current CDC guidance.

## Should cloth face coverings be washed or otherwise cleaned regularly? How regularly?

Yes. They should be routinely washed depending on the frequency of use.

## How does one safely sterilize/clean a cloth face covering?

A washing machine should suffice in properly washing a cloth face covering.

## How does one safely remove a used cloth face covering?

Individuals should be careful not to touch their eyes, nose, and mouth when removing their cloth face covering and wash hands immediately after removing.

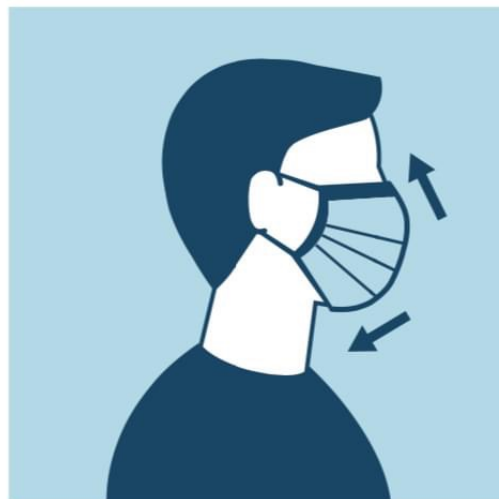

CS316353B 04/04/2020, 12:22 PM

[cdc.gov/coronavirus](https://www.cdc.gov/coronavirus)

# Sewn Cloth Face Covering

## Materials

- Two 10"x6" rectangles of cotton fabric
- Two 6" pieces of elastic (or rubber bands, string, cloth strips, or hair ties)
- Needle and thread (or bobby pin)
- Scissors
- Sewing machine

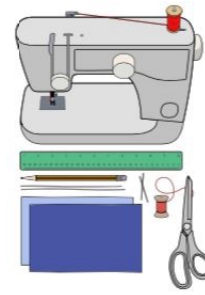

## Tutorial

1. Cut out two 10-by-6-inch rectangles of cotton fabric. Use tightly woven cotton, such as quilting fabric or cotton sheets. T-shirt fabric will work in a pinch. Stack the two rectangles; you will sew the cloth face covering as if it was a single piece of fabric.

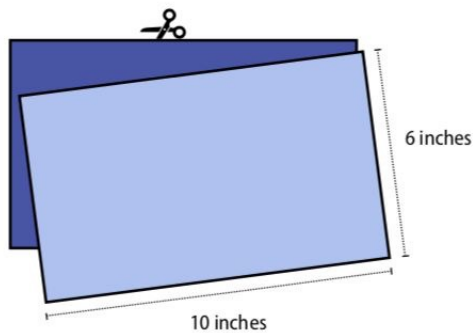

2. Fold over the long sides  $\frac{1}{4}$  inch and hem. Then fold the double layer of fabric over  $\frac{1}{2}$  inch along the short sides and stitch down.

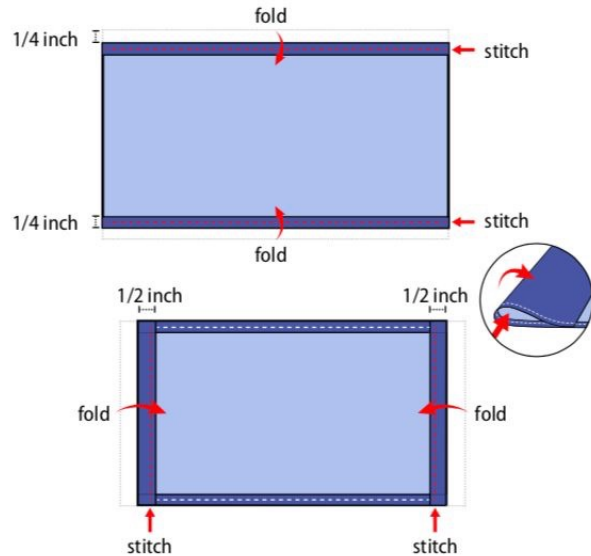

3. Run a 6-inch length of  $\frac{1}{8}$ -inch wide elastic through the wider hem on each side of the cloth face covering. These will be the ear loops. Use a large needle or a bobby pin to thread it through. Tie the ends tight. Don't have elastic? Use hair ties or elastic head bands. If you only have string, you can make the ties longer and tie the cloth face covering behind your head.

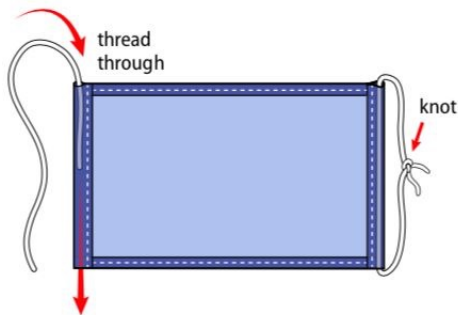

4. Gently pull on the elastic so that the knots are tucked inside the hem. Gather the sides of the cloth face covering on the elastic and adjust so the cloth face covering fits your face. Then securely stitch the elastic in place to keep it from slipping.

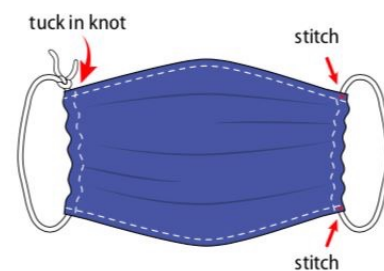

# Sewn Cloth Face Covering

## Materials

- Two 10"x6" rectangles of cotton fabric
- Two 6" pieces of elastic (or rubber bands, string, cloth strips, or hair ties)
- Needle and thread (or bobby pin)
- Scissors
- Sewing machine

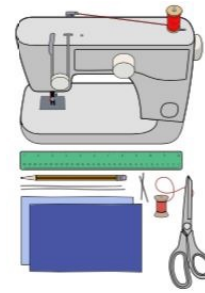

## Tutorial

1. Cut out two 10-by-6-inch rectangles of cotton fabric. Use tightly woven cotton, such as quilting fabric or cotton sheets. T-shirt fabric will work in a pinch. Stack the two rectangles; you will sew the cloth face covering as if it was a single piece of fabric.

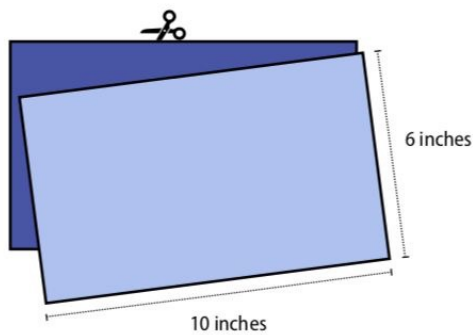

2. Fold over the long sides  $\frac{1}{4}$  inch and hem. Then fold the double layer of fabric over  $\frac{1}{2}$  inch along the short sides and stitch down.

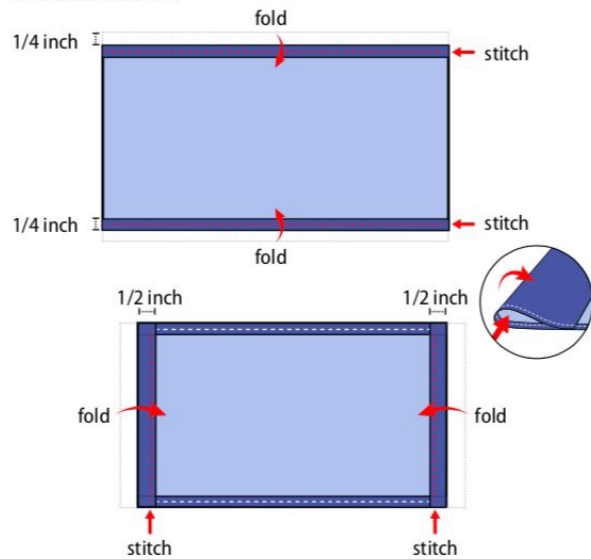

3. Run a 6-inch length of  $\frac{1}{8}$ -inch wide elastic through the wider hem on each side of the cloth face covering. These will be the ear loops. Use a large needle or a bobby pin to thread it through. Tie the ends tight. Don't have elastic? Use hair ties or elastic head bands. If you only have string, you can make the ties longer and tie the cloth face covering behind your head.

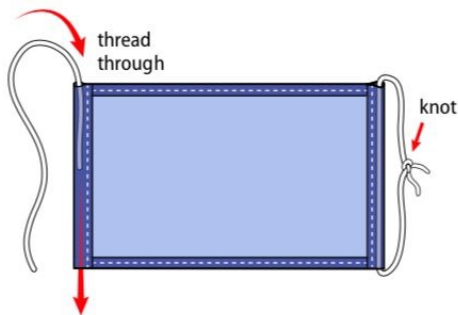

4. Gently pull on the elastic so that the knots are tucked inside the hem. Gather the sides of the cloth face covering on the elastic and adjust so the cloth face covering fits your face. Then securely stitch the elastic in place to keep it from slipping.

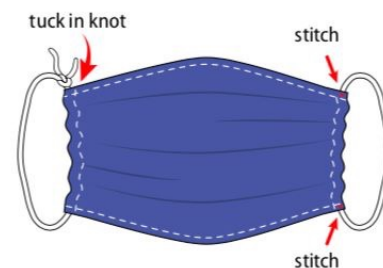



## Quick Cut T-shirt Cloth Face Covering (no sew method)

### Materials

- T-shirt
- Scissors

### Tutorial

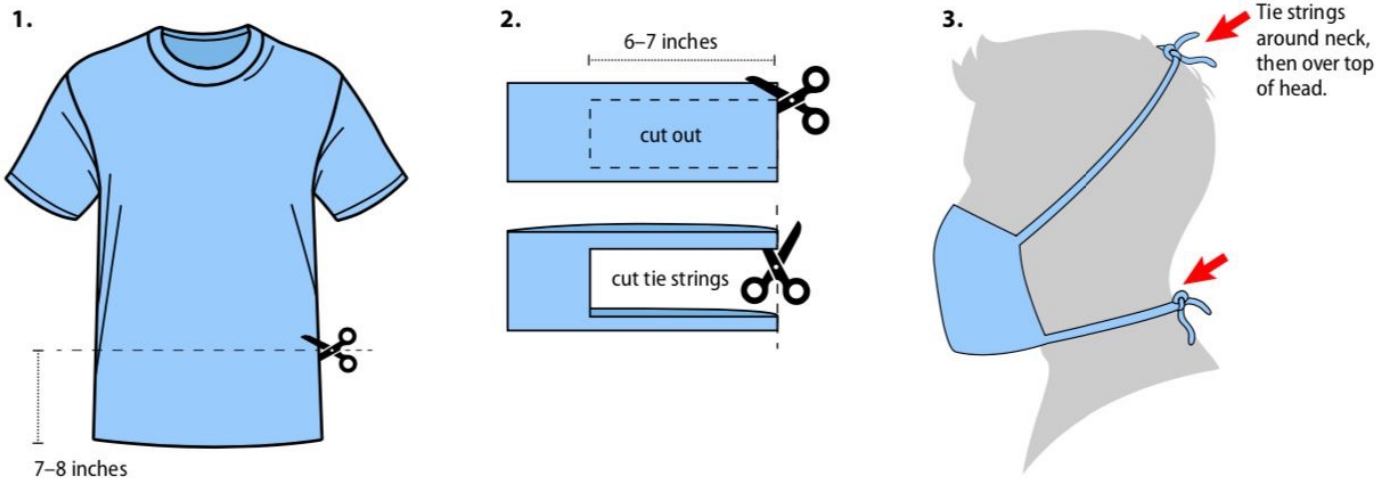

## Bandana Cloth Face Covering (no sew method)

### Materials

- Bandana (or square cotton cloth approximately 20"x20")
- Coffee filter
- Rubber bands (or hair ties)
- Scissors (if you are cutting your own cloth)

### Tutorial

